

CIRCUMFERENTIAL PISTON PUMP



Revolution[®]

Increase your expectations!



wright flow
TECHNOLOGIES[®]

Capacity to 190 m³/hr / 836 USGPM

Pressure to 31 BAR / 450 PSI

Viscosity to 440,000 cSt / 2,000,000 SSU

Temperature to 150°C / 300°F

PATENT PENDING

HYGIENIC PUMP SOLUTIONS

IDEX
CORPORATION

CHEMICAL
Raw Ingredients, Chemical Transfer, Solvent Recovery

PERSONAL CARE
Skin Care Products, Toothpastes, Cosmetics, Shower & Shaving Liquids, Hair Care Products

BEVERAGES
Distillers & Vinters, Fruit & Vegetable Purees, Carbonated Drinks, Juices

FOOD
Baby Food, Edible Oils, Soft Fruits & Vegetables, Soups & Sauces, Egg, Fish, Meat, Poultry, Whey Proteins, Confectionary

DAIRY
Butter, Cheese, Cream, Milk, Yogurt, Yogurt Fruits

BIO PHARMACEUTICAL
Creams & Ointments, Ferment, Injectables, Ultra Filtration, Blood & Plasma Processing

Raw Ingredients, Chemical Transfer, Solvent Recovery

Liquids, Hair Care Products, Cosmetics, Shower & Shaving Skin Care Products, Toothpastes

Drinks, Juices, Vegetable Purees, Carbonated Distillers & Vinters, Fruit &

Proteins, Confectionary, Egg, Fish, Meat, Poultry, Whey & Vegetables, Soups & Sauces, Baby Food, Edible Oils, Soft Fruits

Yogurt, Yogurt Fruits, Butter, Cheese, Cream, Milk

& Plasma Processing, Injectables, Ultra Filtration, Blood Creams & Ointments, Ferment

WRIGHT FLOW ADVANTAGE

Raise the bar on performance & ease of maintenance with the Revolution. Revolution is the first circumferential piston pump in the industry with front loading seals. Also, it is the only pump

available that can be configured with CPP or RLP technologies. A Wright Flow Circumferential Piston Pump is completely positive across the pressure range when the viscosity is above 200 cSt.

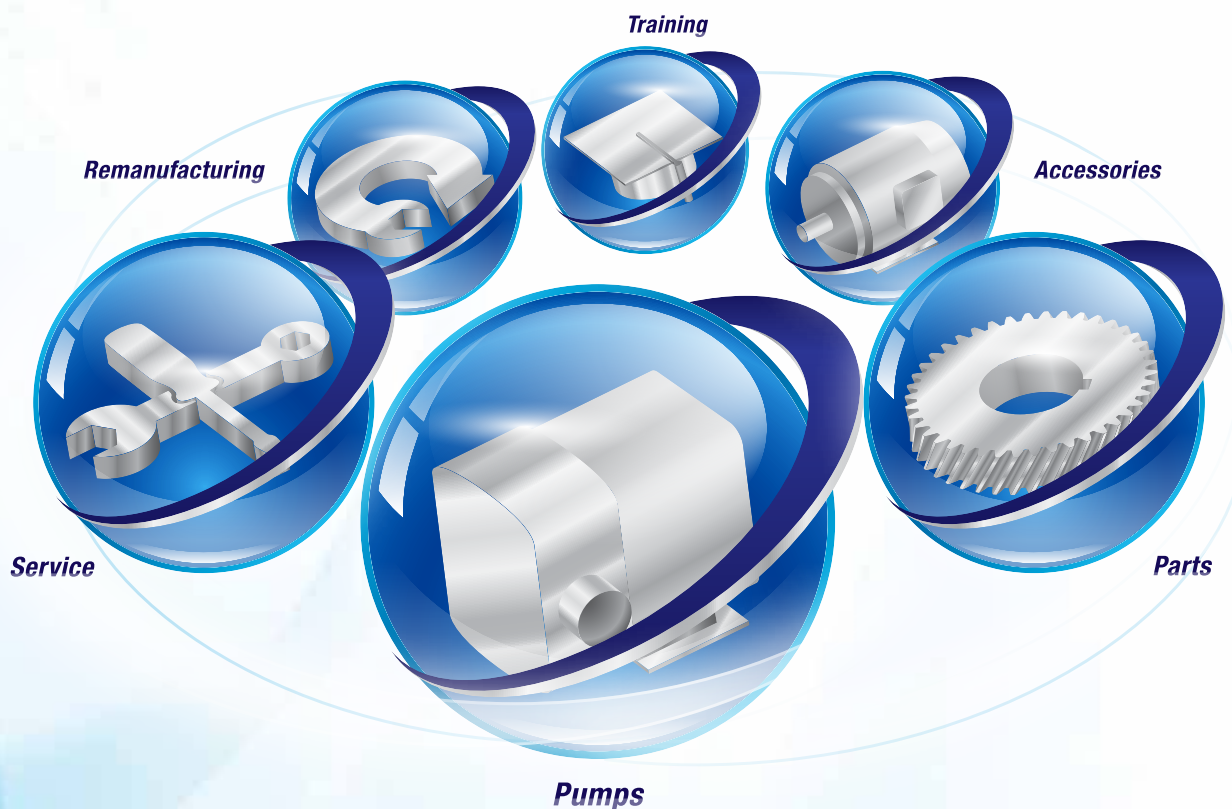

HOW IT WORKS

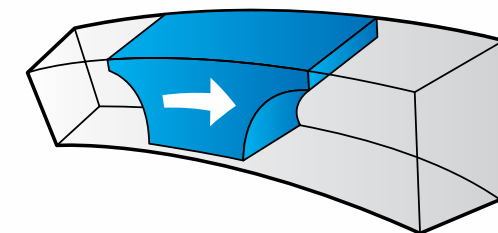

The deep channels in which the rotors travel provide large voids to minimize shear and bruising of solids.

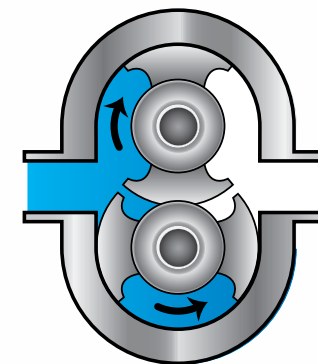

Suction

Wright Flow Technologies rotor wings (pistons) rotate around the circumference of the channel in the pump casing. This continuously generates a partial vacuum at the suction port as the rotors unmesh, causing fluid to enter the pump.

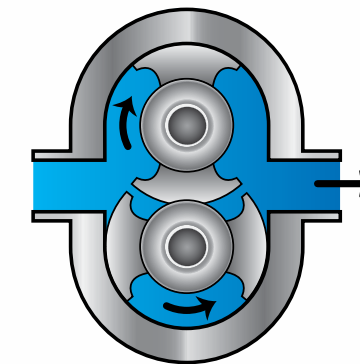

Discharge

The fluid is transported around the channel by the rotor wings, and is displaced as the rotor wings re-mesh, generating pressure at the discharge port. Pump output is directly proportional to speed, and direction of flow is reversible.

CLEANABILITY

- Efficient CIP (clean-in-place) ability is standard for all Revolution pumps
- No dead zones on front cover

EASE OF MAINTENANCE

- Fast, front loading seal changes while pump is still in-line
- Easy access shimming for setting rotor clearance
- Heavy duty shafts give up to 50% longer life, reducing maintenance and lost production time
- 100% of gearbox components are identical for all combinations within a gearbox size and pump principle, giving lower spares stock handling and greater interchangeability

PERFORMANCE

- Improved volumetric efficiency in low & high viscosity applications
- Innovative rotor design reduces shear & pulsation effect
- Exclusive, non-galling WFT 808® alloy rotors standard; permits running at tighter clearances
- Long-life durability from heavy duty shafts & gearcase

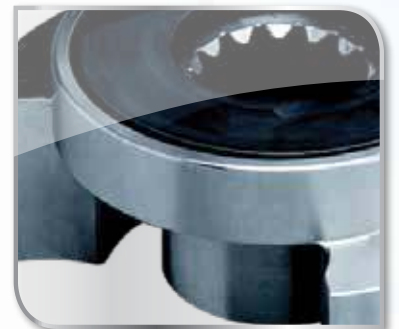

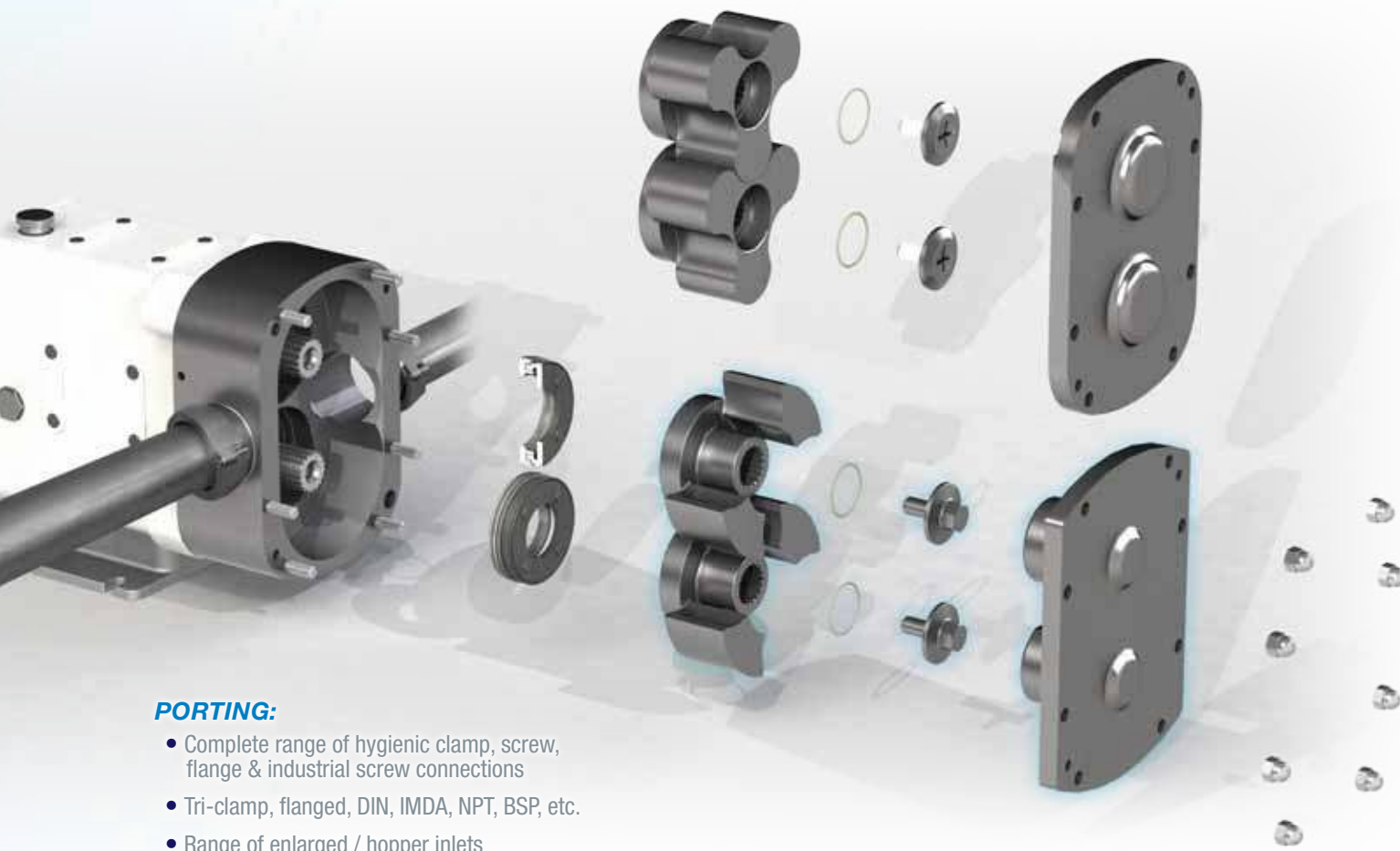

PORTING:

- Complete range of hygienic clamp, screw, flange & industrial screw connections
- Tri-clamp, flanged, DIN, IMDA, NPT, BSP, etc.
- Range of enlarged / hopper inlets

SEALS:

- Single O-ring running on a replaceable sleeve
- Double O-ring w/ flush running on a replaceable sleeve
- Single mechanical
- Double mechanical w/ flush
- Complete range of material options

GEAR BOX:

- Powder coating standard
- Gamma seal protection for gear box oil seals standard
- Stainless steel optional on frame sizes 2-4
- Oil lubrication standard, grease optional

ROTOR & CASING:

- 316L stainless steel pump casing w/ interior finished to 3-A standards
- Non-galling WFT 808® nickel alloy standard or 316L stainless steel rotors
- Improved surface finishes & electropolishing optional

ROTOR CASE INTERNAL SURFACE FINISH:

- 0.8 µm (32 µin) standard
- internal finishes:m/c to 0.6µm (24 µin)
- Mech. polish to 0.5µm (20 µin) or better
- Optional for non hygienic applications
- 1.6µm internals & as cast externals (64 µin)

HEATING & COOLING:

- 4.0 Bar operating pressure
- -20°C (-4°F) to +150°C (302°F)
- Pumps may be fitted with front cover and rotor case jackets when required

TEMPERATURE RATING:

- 90°C (200°F), 150°C (302°F)
- Front face & chocolate

Complete offering of coatings, finishes, materials & options available upon request.

PERFORMANCE RANGE:

- CAPACITY** to 190 m³/hr / 836 USGPM
- PRESSURE** to 31 BAR / 450 PSI
- VISCOSITY** to 440,000 cSt / 2,000,000 SSU
- TEMPERATURE** to 150°C / to 300°F

COMPLIANT WITH THE FOLLOWING STANDARDS



Size	Revolution CPP Model*	Displacement		Max Pressure		Max Speed RPM	Standard Ports		Max Capacity		Max Temperature	
		l/rev.	USG/rev.	BAR	PSI		mm	in.	m³/hr	USG/min.	Deg. C	Deg. F
2	R0150X	0.055	0.014	21	305	800	38.1	1.5	2.6	11	150°	300°
	R0180P	0.11	0.029	14	203	800	38.1	1.5	5.3	23	150°	300°
3	R0200X	0.16	0.04	21	305	800	38.1	1.5	8	34	150°	300°
	R0300X	0.23	0.06	17	247	800	38.1	1.5	11	48	150°	300°
	R0400X	0.29	0.08	14	203	800	50.8	2	14	62	150°	300°
4	R0450X	0.42	0.1	31	450	600	50.8	2	15	67	150°	300°
	R0600P	0.58	0.2	21	305	600	63.5	2.5	21	92	150°	300°
	R0800X	0.77	0.2	17	247	600	63.5	2.5	28	122	150°	300°
	R1300X	1	0.3	14	203	600	76.2	3	36	159	150°	300°
5	R1800X	1.46	0.4	31	450	600	76.2	3	53	231	150°	300°
	R1830X	1.46	0.4	31	450	600	76.2	3	53	231	150°	300°
	R2200X	1.98	0.5	21	305	600	101.6	4	71	313	150°	300°
	R2230X	1.98	0.5	21	305	600	101.6	4	71	313	150°	300°
	R2600P	2.52	0.7	14	203	600	101.6	4	91	399	150°	300°
	R2630P	2.52	0.7	14	203	600	101.6	4	91	399	150°	300°
6	R3200P	3.00	.800	21	305	600	152.4	6.0	108	476	150°	300°
	R3230P	3.00	.800	21	305	600	152.4	6.0	108	476	150°	300°
	R3800P	3.80	1.00	14	203	600	152.4	6.0	138	606	150°	300°
	R3830P	3.80	1.00	14	203	600	152.4	6.0	138	606	150°	300°
	R3900P	4.80	1.30	8	116	600	152.4	6.0	173	761	150°	300°
	R3930P	4.80	1.30	8	116	600	152.4	6.0	173	761	150°	300°
7	R4230P	6.20	1.60	28	400	400	152.4	6.0	148	652	150°	300°
	R5230P	9.00	2.40	14	200	350	203.2	8.0	190	836	150°	300°

*Models ending with 30 are Aseptic Models

Size	Revolution Rectangular Flange Model	Displacement		Max Pressure		Max Speed RPM	Inlet (WxL)		Outlet		Max Capacity		Max Temperature	
		l/rev.	USG/rev.	BAR	PSI		mm	in.	mm	in.	m³/hr	USGPM	Deg. C	Deg. F
3	0340	0.23	0.06	17	247	800	47 x 173	1.85 x 6.81	50.8	2	11	48	150	300
4	0640	0.58	0.2	21	305	600	60 x 226	2.36 x 8.90	63.5	2.5	21	92	150	300
	1340	1	0.3	14	203	600	81 x 236	3.19 x 9.29	76.2	3	36	159	150	300
5	2240	1.98	0.5	21	305	600	103 x 285	4.06 x 11.22	101.6	4	71	313	150	300

Revolution[®]

Increase your expectations!



- ⊗ Ease of Maintenance
- ⊗ Exceptional Cleanability
- ⊗ Long Life Durability

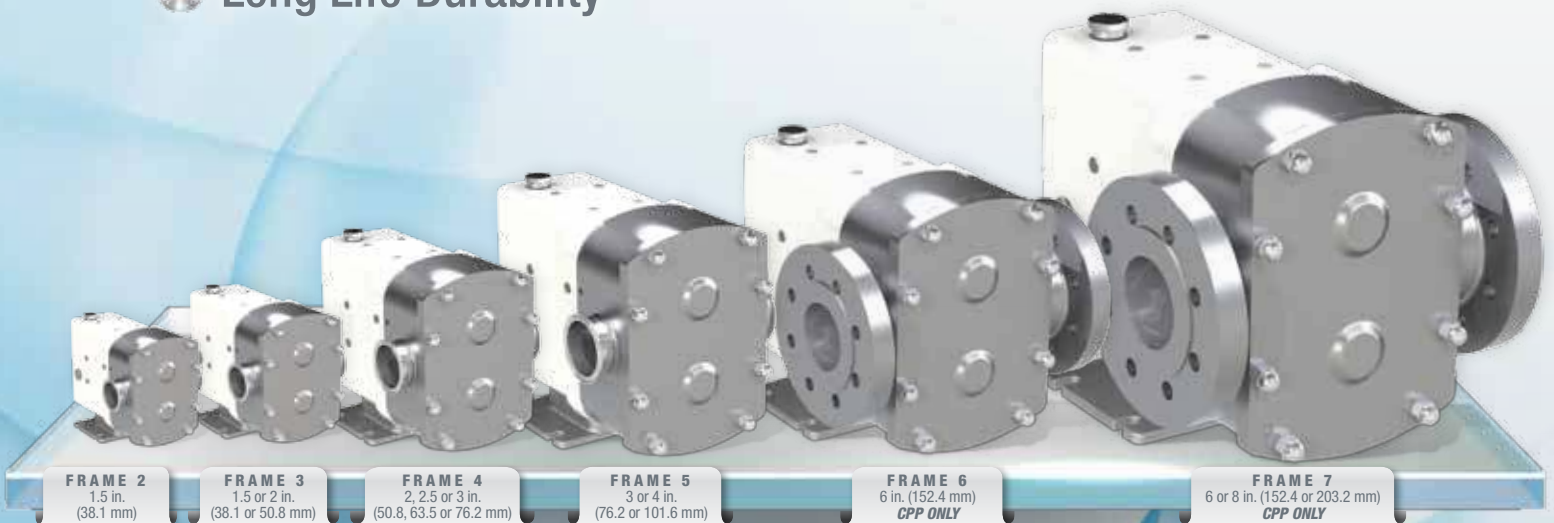

FRAME 2
1.5 in.
(38.1 mm)

FRAME 3
1.5 or 2 in.
(38.1 or 50.8 mm)

FRAME 4
2, 2.5 or 3 in.
(50.8, 63.5 or 76.2 mm)

FRAME 5
3 or 4 in.
(76.2 or 101.6 mm)

FRAME 6
6 in. (152.4 mm)
CPP ONLY

FRAME 7
6 or 8 in. (152.4 or 203.2 mm)
CPP ONLY

wright flow
TECHNOLOGIES[®]

For more information, contact your local authorized Wright Flow Technologies Distributor or contact us at:

Wright Flow Technologies Inc.
406 State Street
Cedar Falls, IA 50613, USA
Phone: (319) 268-8013
E-mail: wright.usa@idexcorp.com

Wright Flow Technologies Ltd.
Highfield Industrial Estate
Edison Road Eastbourne
East Sussex, United Kingdom, BN23 6PT
Phone: +44(0) 1323 509211
E-mail: wright.eu@idexcorp.com
www.wrightflowtechnologies.com

Distributed By:



IDEX
CORPORATION